

Smart Cameras made in Germany



Vision®

Components

The Smart Camera People

VCSBC64XX

Operating Manual

**Hardware Specifications and special Software Functions of
VCSBC64XX Smart Cameras**

Revision 1.2 April 2011

Document name: VCSBC64XX_HW.pdf

© Vision Components GmbH Ettlingen,
Germany

*Vision Components GmbH
Ottostr. 2
76275 Ettlingen
Telefon +49 (0)7243 2167-0
Fax +49 (0)7243 2167-11*

WWW.VISION-COMPONENTS.COM



Foreword and Disclaimer

This documentation has been prepared with most possible care. However Vision Components GmbH does not take any liability for possible errors. In the interest of progress, Vision Components GmbH reserves the right to perform technical changes without further notice.

Please notify support@vision-components.com if you become aware of any errors in this manual or if a certain topic requires more detailed documentation.

This manual is intended for information of Vision Component's customers only. Any publication of this document or parts thereof requires written permission by Vision Components GmbH.

Trademarks







Code Composer Studio and TMS320C6000, Windows XP, Total Commander, Tera Term, Motorola are registered Trademarks. All trademarks are the property of their respective owners.

References under "Support + Download" on www.vision-components.com:

„**Tech News**“ – for up to date information on VC Software and Documentation.

„**Knowledge Base / FAQ**“ - searchable Database with latest software developments, frequently asked questions and demo programs.

“**Download Center**” for all documentation and Software downloads – refer to the following table:

Description	Title on Website	Download Center
Introduction to VC Smart Camera programming	 Programming Tutorial for VC20XX and VC40XX Cameras	Service & Support ▶ Download Center ▶ Documentation ▶ Getting Started VC
Demo programs and sample code used in the Programming Tutorial	 Tutorial_Code	Service & Support ▶ Download Center ▶ Documentation ▶ Getting Started VC
VC4XXX Hardware Manual	 VC4XXX Smart Cameras Hardware Documentation	Service & Support ▶ Download Center ▶ Documentation ▶ Hardware
VCRT Operation System Functions Manual	 VCRT 5.0 Software Manual	Service & Support ▶ Download Center ▶ Documentation ▶ Software
VCRT Operation System TCP/IP Functions Manual	 VCRT 5.0 TCP/IP Manual	Service & Support ▶ Download Center ▶ Documentation ▶ Software
VCLIB 3.0 Image Processing Library Manual	 VCLIB 3.0 Software Manual	Service & Support ▶ Download Center ▶ Documentation ▶ Software



- The Light bulb highlights hints and ideas that may be helpful for a development.



- This warning sign alerts of possible pitfalls to avoid. Please pay careful attention to sections marked with this sign.

Author: VC Support, <mailto:support@vision-comp.com>

Table of Contents

1	General Information	5
2	Basic Structure	6
3	Technical Specifications	7
3.1	Technical specifications VCSBC6438	7
3.2	Technical specifications VCSBC6458	8
3.3	Technical specifications VCSBC6465	9
3.4	Technical specifications VCSBC6466	10
3.5	Technical specifications VCSBC6467	11
3.6	Technical specifications VCSBC6468	12
3.7	Technical specifications VCSBC6472	13
4	Camera Interfaces	14
4.1	ST4: Ethernet connector	15
4.2	ST5: Power Supply and IO Interface	15
4.2.1	Pin Assignments ST5 camera socket	15
4.2.2	Electrical specifications digital IO s ST5 interface	15
4.2.3	Electrical specifications of the VCSBC64XX Power Supply ST5 interface	17
4.2.4	Matching connector and cable for ST5 camera socket	18
4.3	ST6: Trigger and Encoder Interface	19
4.3.1	Pin Assignments ST6 camera socket	19
4.3.2	Electrical specifications ST6 camera interface	19
4.3.3	Matching connector and cable for ST6 camera socket	21
4.4	ST7: Extension Connector	22
4.4.1	Pin Assignments ST7 camera socket	22
4.4.2	Electrical specifications ST7 camera socket	23
4.4.3	Matching connector and cable for ST7 camera socket	23
4.4.4	Recommended external Line Driver / Receiver Circuit for use of the RS232 interface	24
5	Accessories	25
6	Programming VCSBC64XX Cameras	27
6.1	Special Software requirements for the VCSBC64XX	27
6.2	Ethernet Communication	28
6.3	Using FTP with the VCSBC64XX	28
6.4	Preventing Autoexec Execution / IP number reset	28
6.4.1	Resetting the Camera with help of the VCnet Recovery Tool	29
6.5	Special VCRT functions for programming VCSBC64XX cameras	30
6.5.1	General settings	30
6.5.2	Compiling and linking with the VCSBC64XX	30
6.5.3	Image capture with VCSBC64XX cameras	30
6.5.4	IO Ports Functions	31
Appendix A:	New VCRT Functions VCSBC64XX	A
Appendix B:	Spectral Transmission of IR Filter	B

Appendix C:	Overall Dimensions VCSBC64XX	C
Appendix D:	Drawing Circuit Board VCSBC64XX	D
Appendix E:	Drawing C-mount Camera Head VCSBC64XX	D
Appendix E:	Drawing C-mount Camera Head VCSBC64XX	E
Appendix F:	Drawing heatsink VCSBC64XX	F

1 General Information



VCSBC64XX Single Board Camera with two mounted sensor boards

The **VCSBC64XX** is an extremely fast and innovative intelligent Stereo single board camera series and one of the fastest intelligent cameras all over with a computational power of 7200 MIPS. It has 256 MB DDR-RAM, 32 MB Flash EPROM for program and data storage and can be equipped with multiple head options.

Like with all VC Smart Cameras with Texas Instruments DSP, the operation system VCRT allows multitasking. This means for instance that user interface commands can execute in parallel without stopping the inspection process.

The **VCSBC64XX** has a video output onto a PC via 1 Gigabit Ethernet interface and also a High-Speed Trigger input with absolute constant capture delay, which allows absolutely jitter-free image acquisition and high precise synchronizations of the two heads even at very high-speed processes. 12-24 V digital IOs, additional IO ports and an RS232 serial interface are available as well.

Whereas a standard progressive scan camera gets a trigger, starts exposure and then reads out the pixel data, the VCSBC64XX has optimized the image acquisition process so that exposure, image transfer into memory and image processing can be done in parallel. This means if exposure time and image processing time is not longer than the transfer time, the full frame rate can be maintained.

The **VCSBC64XX** offers thus an extremely inexpensive entrance into the world of smart 3D applications.

2 Basic Structure

The image is formed by a high-resolution progressive scan CCD sensor. One channel of video input is digitized. The image is stored in SDRAM memory using one of the 64 DMA channels (EDMA).

Unlike most other Vision Component Smart Cameras, the VCSBC64XX does not have a direct video output. However if monitoring of the camera image is required, this can be done by downloading via Fast Ethernet port to PC and display on screen.

The TMS320C64+ DSP is one of the fastest 32bit DSPs. It features a RISC-like instruction set, up to 8 instructions can be executed in parallel, a L1 cache memory (32 Kbytes) and a 256 Kbytes L2 cache on chip. Its high speed 64-channel DMA controller gives additional performance. The DSP uses fast external DDR-SDRAM as main memory. A flash EPROM provides non-volatile memory.

Block diagram VCSBC64XX Smart Camera

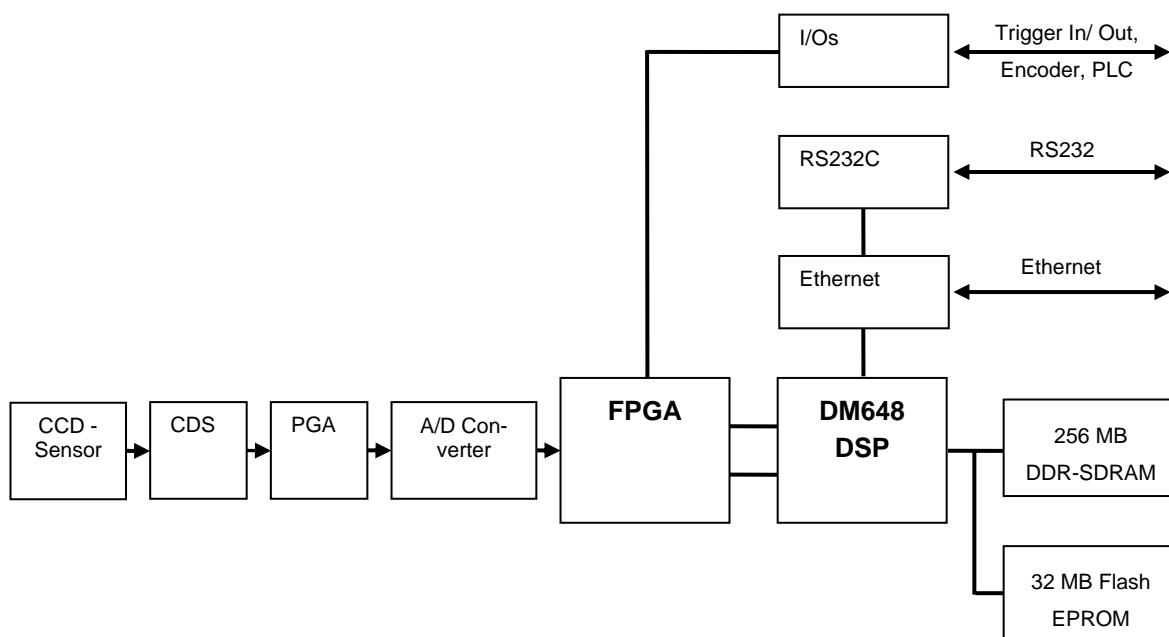

3 Technical Specifications

3.1 Technical specifications VCSBC6438

Component / Feature	Specification
Sensor:	1/3 " SONY ICX424AL - also available with color sensor (Bayer Filter)
eff. no. of pixels:	640(H) x 480(V)
Pixel size:	7.4 μm (H) x 7.4 μm (V)
Chip size:	5.79 mm (H) x 4.89 mm (V)
Integration:	full-frame progressive scan
Picture taking:	program-controlled or triggered externally; full-frame / 63 frames per second
Binning	2 times binning, 126 frames/s, 640(H) x 240(V)
Shutter	5 μs , 10 μs , 15 μs , 19 μs , ... + steps of 31 μs up to 8s
Clamping:	zero offset digital clamping
A/D conversion:	1 x 25 MHz / 10 bit
Input LUT	none
Image display:	Via Gigabit Ethernet onto PC
Processor:	Texas Instruments 900 MHz TMS320DM648 DSP
RAM:	256 MB DDR SDRAM
Flash EPROM:	32 MB
SD card	Not available
Process interface:	4 inputs / 4 outputs, optically decoupled 24 V, outputs 4x400 mA
Trigger input:	Fast 5 V CMOS input and output, jitter free image acquisition
Additional IO ports:	8 I/O ports CMOS 3.3V, I2C Clock and Data signals
Ethernet interface:	Gigabit Ethernet
Serial Interface:	115,200 bd serial RS232 communication port
CE certification:	No CE Certification from Vision Components as the OEM customer is required to certify entire system (including housing, cabling, etc.)
Storage Conditions	Temperature: -20 to 60 deg C, Max. humidity: 90%, non cond.
Operating Conditions	Temperature: 0... +50 deg C (housing temperature), Max. humidity: 80%, non condensing.
Power Supply / Consumption	12 - 24V / max 8,5 W, digital IOs supplied additional

3.2 Technical specifications VCSBC6458

Component / Feature	Specification
Sensor:	1/3"Kodak KAI-0340
eff. no. of pixels:	640(H) x 480(V)
Pixel size:	7.4 μm (H) x 7.4 μm (V)
Chip size:	5.87mm (H) x 4.71mm (V)
Integration:	full-frame progressive scan
Picture taking:	program-controlled or triggered externally; full-frame / 180 frames per second
Binning	2 times binning, 360 frames/s, 640(H) x 240(V)
Shutter	5 μs , 10 μs , 15 μs , 19 μs , ... + steps of 8.5 μs up to 2,2s
Clamping:	zero offset digital clamping
A/D conversion:	2 x 50 MHz / 10 bit
Input LUT	none
Image display:	Via Gigabit Ethernet onto PC
Processor:	Texas Instruments 900 MHz TMS320DM648 DSP
RAM:	256 MB DDR SDRAM
Flash EPROM:	32 MB
SD card	Not available
Process interface:	4 inputs / 4 outputs, optically decoupled 24 V, outputs 4x400 mA
Trigger input:	Fast 5 V CMOS input and output, jitter free image acquisition
Additional IO ports:	8 I/O ports CMOS 3.3V, I2C Clock and Data signals
Ethernet interface:	Gigabit Ethernet
Serial Interface:	115,200 bd serial RS232 communication port
CE certification:	No CE Certification from Vision Components as the OEM customer is required to certify entire system (including housing, cabling, etc.)
Storage Conditions	Temperature: -20 to 60 deg C, Max. humidity: 90%, non cond.
Operating Conditions	Temperature: 0... +50 deg C (housing temperature), Max. humidity: 80%, non condensing.
Power Supply / Consumption	12 - 24V / max 8,5 W, digital IOs supplied additional

3.3 Technical specifications VCSBC6465

Component / Feature	Specification
Sensor:	1/2" SONY ICX415AL - also available with color sensor (Bayer Filter)
eff. no. of pixels:	768(H) x 582(V)
Pixel size:	8.3(H) x 8.3(V) μm
Chip size:	7.48(H) x 6.15(V) mm
Integration:	full-frame progressive scan
Picture taking:	program-controlled or triggered externally; full-frame / 55 frames per second
Binning	2 times binning, 110 frames / s, 782(H) x 291(V)
Shutter	5 μs , 10 μs , 15 μs , 20 μs ,... + steps of 28.5 μs up to 7.4s
Clamping:	zero offset digital clamping
A/D conversion:	1 x 33 MHz / 10 bit
Input LUT	none
Image display:	Via Gigabit Ethernet onto PC
Processor:	Texas Instruments 900 MHz TMS320DM648 DSP
RAM:	256 MB DDR SDRAM
Flash EPROM:	32 MB
SD card	Not available
Process interface:	4 inputs / 4 outputs, optically decoupled 24 V, outputs 4x400 mA
Trigger input:	Fast 5 V CMOS input and output, jitter free image acquisition
Additional IO ports:	8 I/O ports CMOS 3.3V, I2C Clock and Data signals
Ethernet interface:	Gigabit Ethernet
Serial Interface:	115,200 bd serial RS232 communication port
CE certification:	No CE Certification from Vision Components as the OEM customer is required to certify entire system (including housing, cabling, etc.)
Storage Conditions	Temperature: -20 to 60 deg C, Max. humidity: 90%, non cond.
Operating Conditions	Temperature: 0... +50 deg C (housing temperature), Max. humidity: 80%, non condensing.
Power Supply / Consumption	12 - 24V / max 8,5 W, digital IOs supplied additional

3.4 Technical specifications VCSBC6466

Component / Feature	Specification
Sensor:	1/3" SONY ICX204AL - also available with color sensor (Bayer Filter)
eff. no. of pixels:	1024(H) x 768(V)
Pixel size:	4.65(H) x 4.65(V) μm
Chip size:	5.8(H) x 4.92(V) mm
Integration:	full-frame progressive scan
Picture taking:	program-controlled or triggered externally; full-frame / 20 frames per second
Binning	2 times binning, 40 frames/s, 1024(H) x 384(V)
Shutter	10 μs , 15 μs , 20 μs , ...+ steps of 61.5 μs up to 16,2s
Clamping:	zero offset digital clamping
A/D conversion:	1 x 20 MHz / 10 bit
Input LUT	none
Image display:	Via Gigabit Ethernet onto PC
Processor:	Texas Instruments 900 MHz TMS320DM648 DSP
RAM:	256 MB DDR SDRAM
Flash EPROM:	32 MB
SD card	Not available
Process interface:	4 inputs / 4 outputs, optically decoupled 24 V, outputs 4x400 mA
Trigger input:	Fast 5 V CMOS input and output, jitter free image acquisition
Additional IO ports:	8 I/O ports CMOS 3.3V, I2C Clock and Data signals
Ethernet interface:	Gigabit Ethernet
Serial Interface:	115,200 bd serial RS232 communication port
CE certification:	No CE Certification from Vision Components as the OEM customer is required to certify entire system (including housing, cabling, etc.)
Storage Conditions	Temperature: -20 to 60 deg C, Max. humidity: 90%, non cond.
Operating Conditions	Temperature: 0... +50 deg C (housing temperature), Max. humidity: 80%, non condensing.
Power Supply / Consumption	12 - 24V / max 8,5 W, digital IOs supplied additional

3.5 Technical specifications VCSBC6467

Component / Feature	Specification
Sensor:	2/3" SONY ICX285AL EXview HAD CCD
eff. no. of pixels:	1280(H) x 1024 (V)
Pixel size:	6,45(H) x 6.45(V) μm
Chip size:	10,2(H) x 8,3(V) mm
Integration:	full-frame progressive scan
Picture taking:	program-controlled or triggered externally; full-frame / 14 frames per second
Binning	2 times binning, 28 frames/s, 1280(H) x 1024(V)
Shutter	5 μs , 10 μs , 15 μs , 20 μs + steps of 67 μs up to 17.59s
Clamping:	zero offset digital clamping
A/D conversion:	1 x 25 MHz / 10 bit
Input LUT	none
Image display:	Via Gigabit Ethernet onto PC
Processor:	Texas Instruments 900 MHz TMS320DM648 DSP
RAM:	256 MB DDR SDRAM
Flash EPROM:	32 MB
SD card	Not available
Process interface:	4 inputs / 4 outputs, optically decoupled 24 V, outputs 4x400 mA
Trigger input:	Fast 5 V CMOS input and output, jitter free image acquisition
Additional IO ports:	8 I/O ports CMOS 3.3V, I2C Clock and Data signals
Ethernet interface:	Gigabit Ethernet
Serial Interface:	115,200 bd serial RS232 communication port
CE certification:	No CE Certification from Vision Components as the OEM customer is required to certify entire system (including housing, cabling, etc.)
Storage Conditions	Temperature: -20 to 60 deg C, Max. humidity: 90%, non cond.
Operating Conditions	Temperature: 0... +50 deg C (housing temperature), Max. humidity: 80%, non condensing.
Power Supply / Consumption	12 - 24V / max 8,5 W, digital IOs supplied additional

3.6 Technical specifications VCSBC6468

Component / Feature	Specification
Sensor:	1/2" SONY ICX205A
eff. no. of pixels:	1280(H) x 1024 (V)
Pixel size:	4.65(H) x 4.65(V) μm
Chip size:	7.6mm (H) x 6.2 (V)
Integration:	full-frame progressive scan
Picture taking:	program-controlled or triggered externally; full-frame / 14 frames per second
Binning	2 times binning, 28 frames/s, 1280(H) x 1024(V)
Shutter	5 μs , 10 μs , 15 μs , 20 μs + steps of 67 μs up to 17.59s
Clamping:	zero offset digital clamping
A/D conversion:	1 x 25 MHz / 10 bit
Input LUT	none
Image display:	Via Gigabit Ethernet onto PC
Processor:	Texas Instruments 900 MHz TMS320DM648 DSP
RAM:	256 MB DDR SDRAM
Flash EPROM:	32 MB
SD card	Not available
Process interface:	4 inputs / 4 outputs, optically decoupled 24 V, outputs 4x400 mA
Trigger input:	Fast 5 V CMOS input and output, jitter free image acquisition
Additional IO ports:	8 I/O ports CMOS 3.3V, I2C Clock and Data signals
Ethernet interface:	Gigabit Ethernet
Serial Interface:	115,200 bd serial RS232 communication port
CE certification:	No CE Certification from Vision Components as the OEM customer is required to certify entire system (including housing, cabling, etc.)
Storage Conditions	Temperature: -20 to 60 deg C, Max. humidity: 90%, non cond.
Operating Conditions	Temperature: 0... +50 deg C (housing temperature), Max. humidity: 80%, non condensing.
Power Supply / Consumption	12 - 24V / max 8,5 W, digital IOs supplied additional

3.7 Technical specifications VCSC6472

Component / Feature	Specification
Sensor:	1/1.8" (8,923mm) SONY ICX274AL
eff. no. of pixels:	1550(H) x 1200 (V)
Pixel size:	4.4µm (H) x 4.4µm (V)
Chip size:	8.5mm (H) x 6.8mm (V)
Integration:	full-frame progressive scan
Picture taking:	program-controlled or triggered externally; full-frame / 10 frames per second
Binning	2 times binning, 20 frames/s, 1550(H) x 600(V)
Shutter	5 µs, 10µs, 15 µs, 20 µs + steps of 48 µs up to 12.5s
Clamping:	zero offset digital clamping
A/D conversion:	1 x 40 MHz / 10 bit
Input LUT	none
Image display:	Via Gigabit Ethernet onto PC
Processor:	Texas Instruments 900 MHz TMS320DM648 DSP
RAM:	256 MB DDR SDRAM
Flash EPROM:	32 MB
SD card	Not available
Process interface:	4 inputs / 4 outputs, optically decoupled 24 V, outputs 4x400 mA
Trigger input:	Fast 5 V CMOS input and output, jitter free image acquisition
Additional IO ports:	8 I/O ports CMOS 3.3V, I2C Clock and Data signals
Ethernet interface:	Gigabit Ethernet
Serial Interface:	115,200 bd serial RS232 communication port
CE certification:	No CE Certification from Vision Components as the OEM customer is required to certify entire system (including housing, cabling, etc.)
Storage Conditions	Temperature: -20 to 60 deg C, Max. humidity: 90%, non cond.
Operating Conditions	Temperature: 0... +50 deg C (housing temperature), Max. humidity: 80%, non condensing.
Power Supply / Consumption	12 - 24V / max 8,5 W, digital IOs supplied additional

4 Camera Interfaces

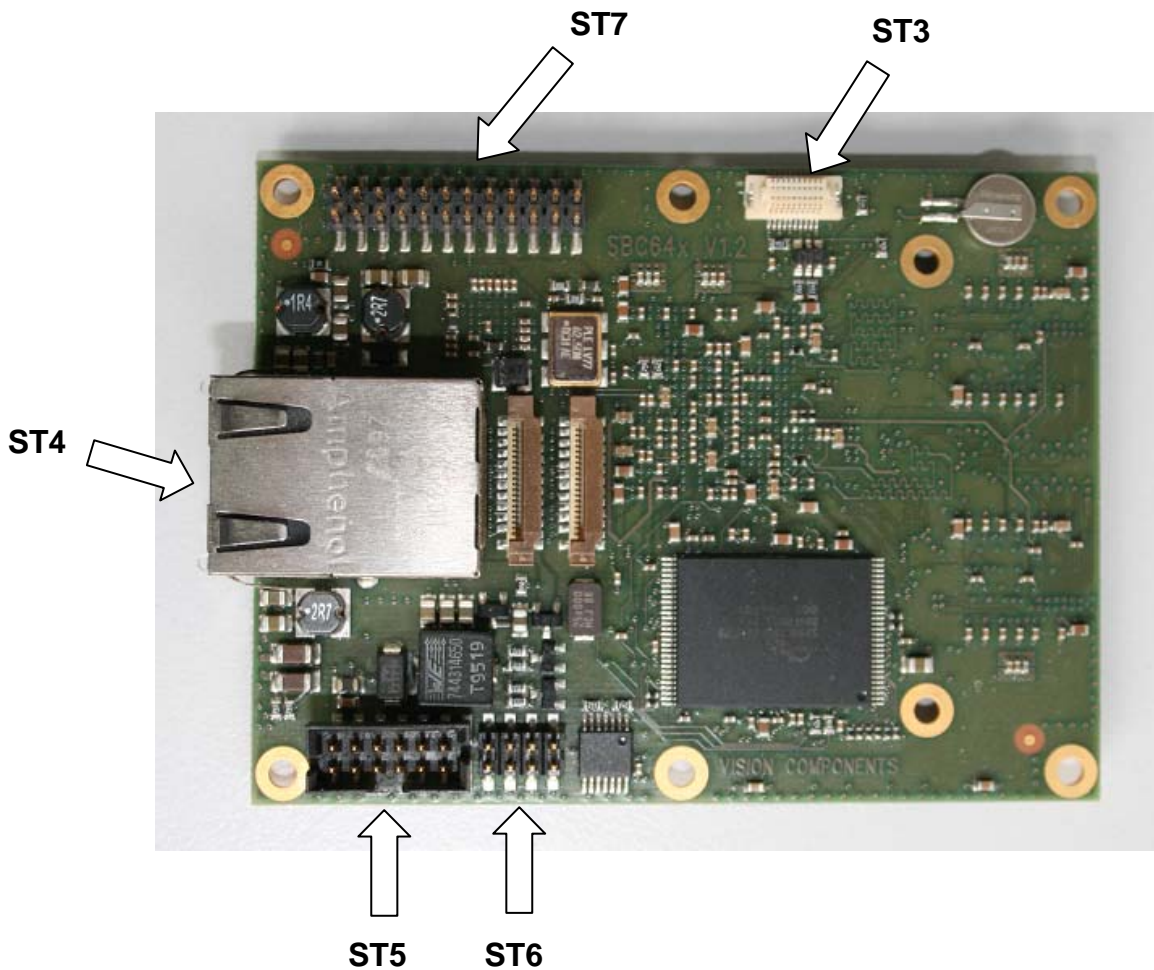

The VCSBC64XX camera board incorporates the following connector interfaces:

- ST3: Emulator (JTAG) Connector
- ST4: Ethernet Connector
- ST5: VCSBC64XX/VCSBC40XX/ VCSBC50 Power and PLC IO Connector
- ST6: Trigger & Encoder Connector
- ST7: Extension Connector (I2C, RS232, IO Ports)

The pin assignments, electrical specifications as well as available accessories are shown for each interface connector in the following sections.

Please refer to [Appendix D: Drawing Circuit Board VCSBC64XX](#) for the pin 1 orientation of the camera board sockets.

4.1 ST4: Ethernet connector

The connector ST4 is a standard Ethernet connector for an RJ45 cable.

Please use at least Category 5 cables!

4.2 ST5: Power Supply and IO Interface

The ST5 connector includes the camera power supply and the digital IOs.

4.2.1 Pin Assignments ST5 camera socket

Pin Number	Signal
1	Out0
2	Power (12-24V)
3	Out1
4	Power GND
5	Out2
6	In3
7	Out3
8	GND
9	In0
10	In2
11	In1
12	GND

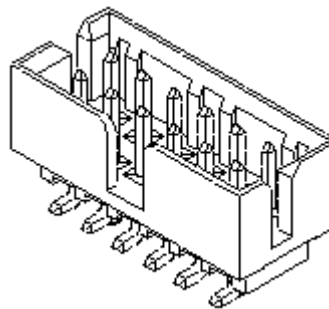

ST5 Standard
VC5BC64XX socket:
Molex: 8783212-20 with
center polarization slot

Pin Locations

2	4	6	8	10	12
1	3	5	7	9	11



Please refer to [Appendix D: Drawing Circuit Board VC5BC64XX](#) for the pin 1 orientation on the camera board socket.

4.2.2 Electrical specifications digital IO s ST5 interface

The camera has 4 PLC compatible inputs and 4 PLC compatible high-current outputs for controlling machines and processes.



Inputs and outputs are not galvanically decoupled from the supply voltage.

A protective diode ensures that the poles of the supply voltage from the power supply of the PLC can not be swapped.

The outputs are floating when low - pull down resistor required.

Input Signals IO interface

Nominal voltage:	12 – 24 V
Absolute maximum voltage:	voltages greater than 40 V can destroy the inputs
Type:	Circuit GND directly connected
Input current:	1 mA @ 24V
Threshold value:	10 V
Internal signal delay:	No delay for direct IO access

The PLC-compatible inputs (24-V level, the positive signal is connected) include input protection circuits. A minimum voltage of 10V is required to reliably sense a logic high signal.

Output Signals IO Interface

Operating voltage:	external source 12 – 24 V
Absolute maximum voltage:	voltages greater than 40 V can destroy the outputs
Type:	Circuit GND directly connected
Switching voltage:	positive switching (PNP)
Current:	max. 400 mA per output
Absolute maximum current:	total currents greater than 1000 mA can destroy plugs and cables Always consider the total sum of all output currents
Switching power:	max. 9.6 W (24 V * 400 mA) per output
Reverse voltage protection	yes, for external voltage
Protection against inductive loads:	yes
Resistance when switched on:	0.2 - 0.8 Ohm
Short circuit protection:	full protection

The PLC outputs feature a highly integrated MOSFET, high-side switch with built-in protection. It is possible to switch inductive or capacitive loads. The protective feature of the outputs will produce pulses on the outputs, if the limiting values are exceeded.

Output drivers feature short circuit end thermal overload protection

4.2.3 Electrical specifications of the VCSBC64XX Power Supply ST5 interface

Nominal Voltage:	12V – 24V
Maximum Power Consumption with one head ¹ :	8.5 W
Minimum operational voltage (including ripple):	9V
Minimum Operating voltage and corresponding current:	12V 700mA ²
Maximum Operating voltage and corresponding current:	24V 350mA ³
Maximum operational Voltage (including ripple):	30V

Power must be connected to the 12 pin ST5 I/O connector.

Camera power is regulated inside the camera, so only an unregulated power source of 12 V to 24V is required. The camera is, however, very sensitive to power supply interruption. Please make sure, that the voltage never exceeds the limits of < 9V, > 30V even for a short period of time. In case of trouble it is recommended to backup the power supply by a capacitor or a battery large enough to prevent power interruptions.

¹ Maximum power consumption without using the PLC output or onboard 3.3V supply.

² Current drawn for PLC outputs and the 3.3V on board signal needs to be added to these figures.

4.2.4 Matching connector and cable for ST5 camera socket

ST5 Standard VCSBC64XX socket: Molex: 8783212-20 with center polarization slot (see above)

The wall socket with polarization slot has been used for this camera in order to avoid camera damage caused by shifted or reversed plug connections.

The standard VCSBC50 cable can be used to prevent shifted plug mounting:

Color code VCSBC50/ VCSBC40XX/VCSBC64XX Power / PLC Cable VK000173:

Pin Number	Signal	
1	Out0	Blue
2	Power (24V)	Red
3	Out1	Purple
4	Power GND	Black
5	Out2	Grey / Red
6	In3	Green
7	Out3	Blue / Red
8	GND	Yellow
9	In0	Grey
10	In2	White
11	In1	Pink
12	GND	Brown

Pin arrangement (looking down on circuit board socket):

2	4	6	8	10	12
1	3	5	7	9	11

▽

Please refer to [Appendix D: Drawing Circuit Board VCSBC64XX](#) for the pin 1 orientation on the camera board socket.

For additional safety against reversed connections (using the with center polarization slot of the socket), please order one of the following connectors from the manufacturer Molex (www.molex.com):

Part numbers: 87568-1263, 87568-1264, 87568-1273, 87568-1274

4.3 ST6: Trigger and Encoder Interface

4.3.1 Pin Assignments ST6 camera socket

Pin Number	Signal
1	5V out
2	Trig_in_A
3	Trig_out_A
4	Trig_in_B
5	Trig_out_B
6	Enc_A
7	Enc_B
8	GND

Pin locations:

2	4	6	8
1	3	5	7



Please refer to [Appendix D: Drawing Circuit Board VCSBC64XX](#) for the pin 1 orientation on the camera board socket.

4.3.2 Electrical specifications ST6 camera interface

Trigger IO Specifications:

The board features two fast CMOS trigger inputs (for use as image capture trigger) and two corresponding CMOS trigger outputs (as strobe-light trigger). Since the signals are fast at a very low noise margin, it is recommended to keep the cable as short as possible. Use twisted pair or even coaxial cable for this purpose. The trigger input assures a constant image capture delay without jitter.



The SBC64XX features at the time only synchronized triggering (both images triggered simultaneously). Trigin A and trigin B must be triggered together (**pins 2 and 4 have to be connected**), otherwise triggering will not work!!

This limitation will be removed with a software update (future version of VCRT).

Electrical Specification of trigger and encoder inputs:

input voltage: Signal LOW	-0.3V – 0.8V
Input voltage: Signal HIGH	2.2V – 5V
input current:	N/A
limiting resistor:	none
reverse voltage protection:	none

Image trigger on rising or falling input signal works as before – see section 6.5.3 for details.



The trigger inputs and outputs are very sensitive and not galvanically separated. Opto isolation of the driving circuit is therefore strongly recommended. The following page shows suitable circuits for trigger inputs and outputs.

Please note that inputs and outputs are not protected against over current. The outputs are neither protected against short circuit nor reverse voltage spikes from inductive loads.

Recommended driving circuit for the trigger inputs:

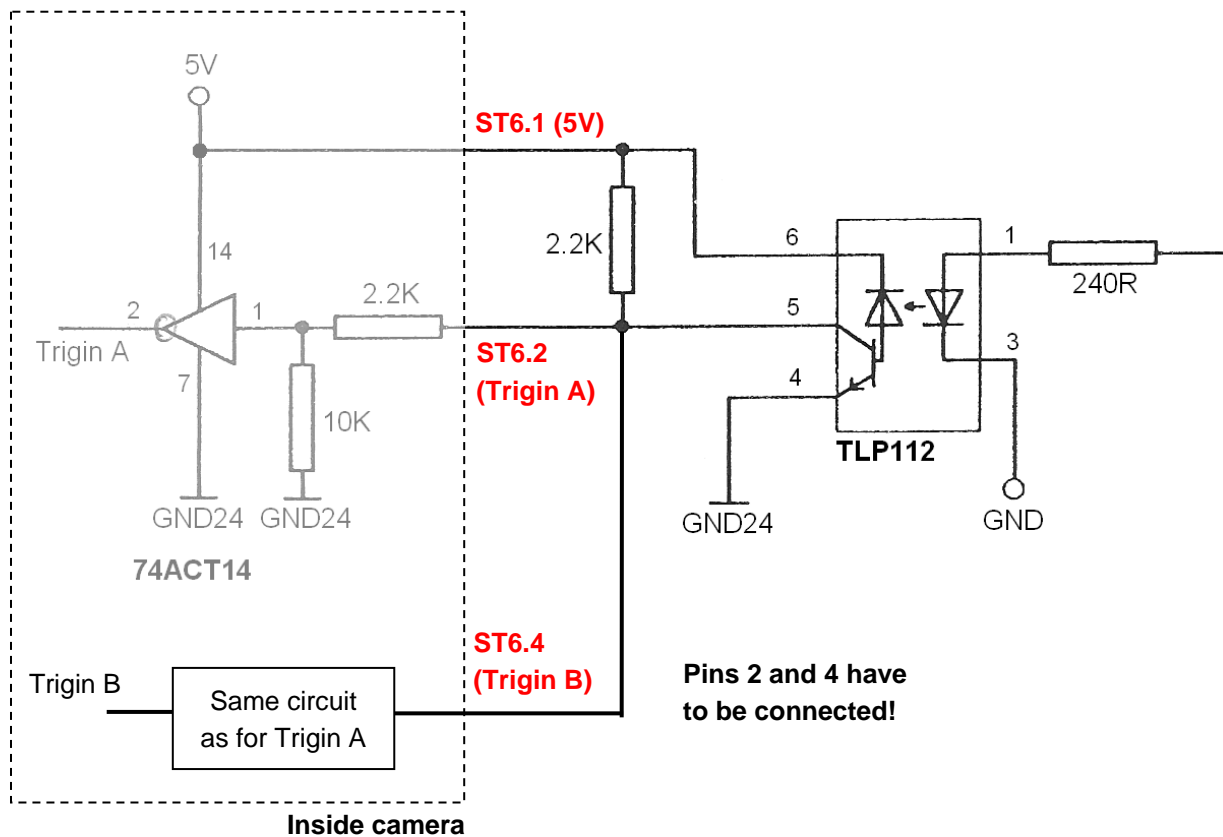

Electrical Specification of trigger outputs:

output voltage signal LOW:	0.45 V with 20mA output current
output voltage signal HIGH:	4.5 V with 20mA output current
Maximum output current:	max. 20 mA
pull-up resistor:	none, LVTTTL push-pull output

Caution: Place the connectors at the correct position – not reversed or shifted. The position of Pin 1 for each connector is marked in **Appendix D: Drawing Circuit Board VCSC64XX**.

Recommended circuit for trigger outputs:

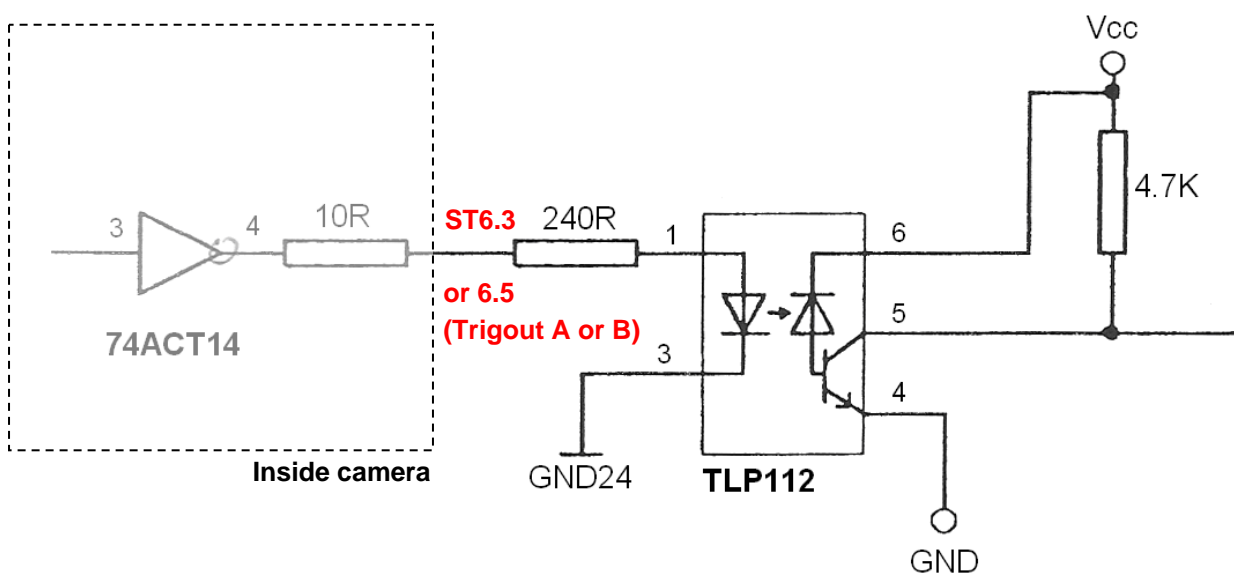

4.3.3 Matching connector and cable for ST6 camera socket

Socket ST6 on circuit board: Part number: 87759-0850, manufacturer: Molex
 Matching connector: Part number: 51110-0850, manufacturer: Molex

Pin assignment Trigger / Encoder cable VK001034:

PIN (J4)	Signal	Cable Color
1	5V out	Blue
2	Trig_in_A	Red
3	Trig_out_A	Purple
4	Trig_in_B	Black
5	Trig_out_B	Pink / Black
6	Enc_A	Green
7	Enc_B	Red / Blue
8	GND	Yellow

4.4 ST7: Extension Connector

Note that the CMOS IOs are very sensitive. Only use driving electronics suitable for CMOS IOs!



4.4.1 Pin Assignments ST7 camera socket

Pin Number	Signal
1	5V
2	I2C_Data
3	I2C_Clock
4	GND
5	3,3 V
6	IO_0
7	IO_1
8	GND
9	IO_2
10	IO_3
11	nReset_out
12	GND
13	25 MHz Out
14	GND
15	IO_4
16	GND
17	IO_5
18	IO_6
19	IO_7
20	GND
21	RS232_RX
22	RS232_TX
23	RS232_RTS
24	RS232_CTS

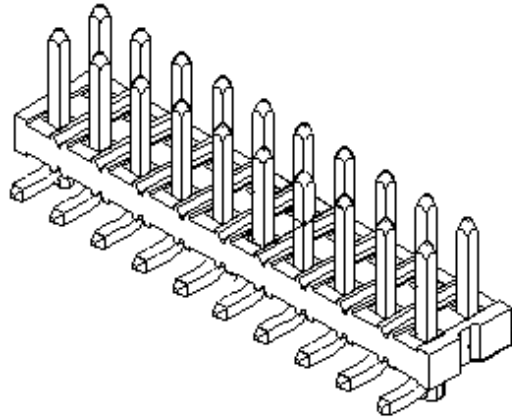

In order to use this serial interface as a RS232 interface, a line driver / receiver circuit is required. A sample circuit is documented in section 4.4.4.

Pin Locations

2	4	6	8	10	12	14	16	18	20	22	24
1	3	5	7	9	11	13	15	17	19	21	23

▽

Please refer to **Appendix D: Drawing Circuit Board VC5BC64XX** for the pin 1 orientation on the camera board socket.

IO_0 – IO_7	Digital CMOS IO ports
5V and 3,3V	5V and 3.3V board main voltage, I _{max} = 50mA
I2C_Clock and I2C_Data	I2C serial Bus Interface for additional peripherals (Refer to the Texas Instruments documentation ³ for further details)
RS232_RX, TX, RTS, CTS	Serial interface

4.4.2 Electrical specifications ST7 camera socket

All signals are Low Level CMOS (3.3V), not opto-isolated.

The following signals have a 4k7 pull up resistor to 3.3V on board:

- I2C_Clock
- I2C_Data

4.4.3 Matching connector and cable for ST7 camera socket

The socket ST7 has the following part number: 8775967-2050, manufacturer Molex (www.molex.com)

Two 12-pin cables VK000173 (same as ST5 connector) are needed.

Pin 1-12 first ST7 cable Pin 13-24 second ST7 cable (pin number of connector given here)

2	4	6	8	10	12	14	16	18	20	22	24
1	3	5	7	9	11	13	15	17	19	21	23

▽

Color code first Cable VK000173 (left socket side):

Pin Number	Signal	Color
1	5V	Blue
2	I2C_Data	Red
3	I2C_Clock	Purple
4	GND	Black
5	3,3 V	Grey / Red
6	IO_0	Green
7	IO_1	Blue / Red
8	GND	Yellow
9	IO_2	Grey
10	IO_3	White
11	nReset_out	Pink
12	GND	Brown

³ “TMS320C6000 DSP Inter-Integrated Circuit (I2C) Module Reference Guide”, Literature Number: SPRU175A, Oct. 2002

Color code second Cable VC000173 (right socket side):

Pin Number	Signal	Color
13	25 MHz Out	Blue
14	GND	Red
15	IO_4	Purple
16	GND	Black
17	IO_5	Grey / Red
18	IO_6	Green
19	IO_7	Blue / Red
20	GND	Yellow
21	RS232_RX	Grey
22	RS232_TX	White
23	RS232_RTS	Pink
24	RS232_CTS	Brown

4.4.4 Recommended external Line Driver / Receiver Circuit for use of the RS232 interface

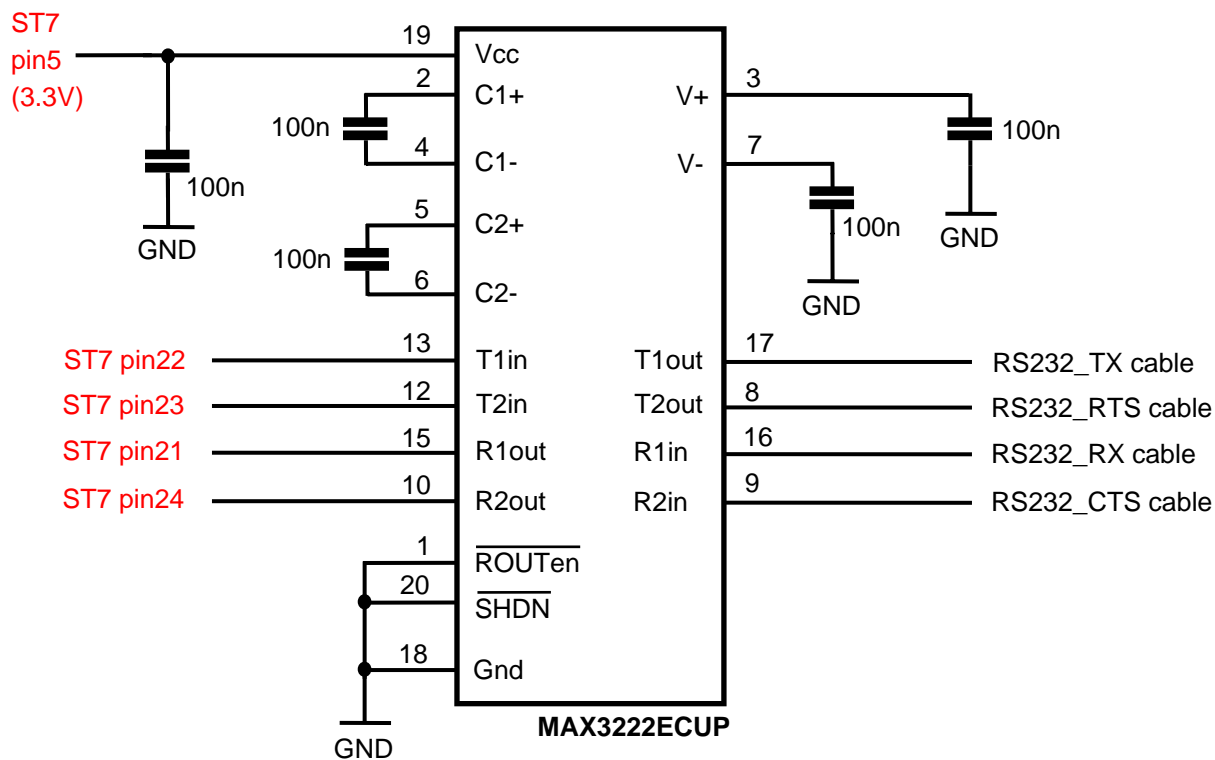

5 Accessories

For interface cables and connectors available also consult the corresponding section in chapter 4 of this manual.



The VCSBC64XX can be used with 12mm threaded micro lenses or C-mount lens holder. Due to the different options these **lens holders have to be ordered separately** to the camera, **as well as the mounting service**. If ordered together, VC ships the camera fully assembled.



The **C-mount flange distance can then be accurately adjusted**.

Please remove the protective foil on the CCD in case the camera has been ordered and delivered without lens holder!



The VCSBC64XX are delivered with one sensor head! For a second sensor head, please order it separately (see table).

Camera, lens holder and head order numbers:

Cameras (one sensor head, no lens holder)	Order Number
VCSBC6438 Single Board Smart Camera without lens holder, b/w CCD	VK000429
VCSBC6438C Single Board Smart Camera without lens holder, Bayer CCD	VK001023
VCSBC6458 Single Board Smart Camera without lens holder, b/w CCD	VK001060
VCSBC6465 Single Board Smart Camera without lens holder, b/w CCD	VK001030
VCSBC6465C Single Board Smart Camera without lens holder, Bayer CCD	VK001033
VCSBC6466 Single Board Smart Camera without lens holder, b/w CCD	VK001025
VCSBC6466C Single Board Smart Camera without lens holder, Bayer CCD	VK001055
VCSBC6467 Single Board Smart Camera without lens holder, b/w CCD	Contact us
VCSBC6468 Single Board Smart Camera without lens holder, b/w CCD	VK001028
VCSBC6472 Single Board Smart Camera without lens holder, b/w CCD	VK001018

Lens holders	Order Number
Lens holder C Mount (IR-Cut Filter EK000625 included)	VK000409
Lens holder C Mount (Clear glass window EK000628 included)	VK000237
Lens holder 12mm	VK000091
Mounting of lens holder	VK000233

Second sensor head (with flat cable 80mm)	Order Number
VCBSC6438 sensor head, without lens holder	VK001038
VCBSC6438C sensor head, without lens holder	VK001040
VCBSC6458 sensor head, without lens holder	VK001063
VCBSC6465 sensor head, without lens holder	VK001042
VCBSC6465C sensor head, without lens holder	VK001044
VCBSC6466 sensor head, without lens holder	VK001045
VCBSC6466C sensor head, without lens holder	VK001049
VCBSC6467 sensor head, without lens holder	Contact us
VCBSC6468 sensor head, without lens holder	VK001050
VCBSC6472 sensor head, without lens holder	VK001052

Further accessories available for the VCSBC64XX:

Product description	Order Number
12-pin cable for Expansion Port ST7 (2 cables needed, as 24-pin connector). It is recommended to manufacture matching circuit board	VK000173
Power Supply and IO Interface 12-pin cable for ST5	VK000173
Trigger and encoder 8-pin cable for ST6 (0.5m length)	VK001034
Flex cables for detached Camera Head mounting:	30mm x 20
	80mm x 20 core ¹
¹ The 80mm flex cable is part of standard delivery.	200mm x 20 core
Clear glass protective sensor window (replaces IR filter in camera head)	EK000321
	EK000322
	EK000629
IR cut filter (camera is shipped with this filter mounted) refer to Appendix B	EK000628
	EK000625

All cable lengths are 0.5m unless stated otherwise.

Please also refer to the VC website www.vision-components.com for an up to date list of accessories.

6 Programming VCSBC64XX Cameras

The VCSBC64XX operating system includes some additional functions, mainly for the control of the additional interfaces. Without direct VGA output some video control functions are not implemented for this camera.

This manual describes the differences between the standard VCRT 5 operating system functions and the special function library of the VCSBC64XX. For programming please also consult the [VCRT 5](#) and [VCLIB 2.0 and VCLIB 3.0 manuals](#) (see the list of references at the beginning of this manual).

6.1 Special Software requirements for the VCSBC64XX

The following table shows the minimum compatible setup options using the VCSBC64XX camera:

Code Composer Studio Version	VCRT PC Lib Version	VCLIB Version	VCRT Camera OS Version:
CCS 3.3 or CCS 4.x (C6000)	VCRT 5.29	VCLIB 3.10	VCRT 5.29.2

Refer to the “**Tech News**” section, under “Support and Download” on the VC website for an overview of the latest compatible set up.

The VCRT PC lib Operation System PC library, the VCLIB Image Processing Library as well as the VCRT Camera Operation System can be downloaded from Support section of the Vision Components Website.

Software manuals are located in the “Registered User Area”. This download area can be accessed after registration and log in on the VC Website.

Software updates are available from the “Customer Area”. For access to the customer area please register your Vision Components development software for VC cameras with TI processor. Software registration can be done after logging in using the license key code shipped with each development bundle. For this please follow the “Register your Software” link under the “User Menu”.

6.2 Ethernet Communication

The default camera IP address is 192.168.0.65 – as with all Ethernet cameras from VC.

The IP address can be changed to a different loading a #IP file into camera memory.

Refer to the “Getting Started VC Smart Cameras” guide for further details.

The camera supports DHCP server IP address allocation. In order to use DHCP allocation, the entry “DHCP” needs to be added to the #IP file as shown:

```
DHCP
IP: 192.168.0.81
MSK: 255.255.255.0
GTW: 192.168.0.1
```

The camera uses the specified IP address if DHCP allocation is not successful. If no IP address is specified in the #IP file, the camera falls back to the default address:

```
192.168.0.65
```



Please use DHCP server functions to determine the IP address allocated to the camera. Most server show a list of mac addresses and corresponding IP addresses or allow to allocate fixed IP addresses to a certain mac address. Determine the mac address of the camera using the shell command “type #ID” to prior to using DHCP IP address allocation!

The “Getting Started VC Smart Cameras” and section 6.4.1 include advice on re-setting a camera with unknown or invalid IP Address.

6.3 Using FTP with the VCSBC64XX

The use of any standard ftp client is now possible. The following server commands have been added: SYSTEM,PWD,CWD,LIST,DEL

Programs have to be uploaded as “out” files into the camera flash memory. Ascii files like the autoexec or #IP files can be uploaded as “*.txt” files – the conversion into *.msf” files is not required.

6.4 Preventing Autoexec Execution / IP number reset

Preventing the execution of an Autoexec file by attempting a connection with the camera (as described in the programming tutorial) does not work, due to the increased processor speed.

Resetting the camera using a keypad as with the VC20XX cameras is also not possible.

There are three ways of preventing the Autoexec execution and resetting the IP address:

Option 1:

1. Upload an empty autoexec/ #IP file via FTP into the camera memory, overwriting the existing file(s).
2. Hardware reset of camera.

Option 2: CPU reset with help of an Emulator.

Option 3: Resetting the camera with help of the “VCnet Recovery Tool” as described in the following section.

6.4.1 Resetting the Camera with help of the VCnet Recovery Tool

A new tool – the “Vcnet Recovery Tool” is provided for resetting the IP address of the TI-based VC Smart Cameras from VC4XXX. Vcnet Recovery is supported from camera OS VCRT 5.21.

In order to use the VCnet Recovery tool, follow the steps below:

1. Download and install the “**Java(TM) 2 Runtime Environment, Standard Edition 1.4.XX**” on your PC (Download from www.sun.com - > Downloads - > J2SE v 1.4.2_11 JRE).
2. Download **VCnet Recovery Tool for VC40XX and VCSBC40XX** from www.vision-comp.com -> Service & Support.
3. Unpack the “vcnet1.2.zip” folder a directory on your hard drive (for instance C:\ti\Util...).
4. Open the Dos command line window and change to the directory containing “vcnet.jar”.
5. Execute the following command from the DOS Window "java -jar vcnet.jar -snr 5912345" , by specifying the camera serial number as shown. This command sends vcp packets via UDP broadcast for the next 15 seconds. Sending this command resets the corresponding camera to the default IP address and bypasses Autoexec execution. Further options below.
6. Boot the corresponding camera (power on) during the next 15 seconds. During start up the camera listens 0.5 seconds for cvp packets send with vcnet.jar.
7. If a valid vcp packet is received from camera an answer packet is sent (see example below). The camera continues booting in standard configuration:

Default IP address:	192.168.0.65
Mask:	255.255.255.0
Gateway:	none

An autoexec in flash memory is not executed.

Example of resetting a VCSBC40XX, S/N 0100151:

```
C:\Programme\VCnet>java -jar vcnet.jar -snr 0100151
VCnet Recovering Tool Version 1.2 - Copyright Vision Components 2005

Recovering Serial Number = 100151

Listening on port 67 for incoming packets!

Packet 2 from: /0.0.0.0

===Data as Text:===

model: VC4018E
S/N: 0100151
DC: 06/10/05 09:23:06
MAC: 00-06-1F-01-87-37
IP: 192.168.0.81
MSK: 255.255.255.0
GTW: 192.168.0.1
....
```

6.5 Special VCRT functions for programming VCSBC64XX cameras

This section explains the specifics of programming VCSBC64XX cameras.

6.5.1 General settings

Programming the VCSBC64XX requires at least the VCRT library version 5.29.6.



To ensure proper functioning of all features of the VCSBC64XX, the following define is needed (has to be defined BEFORE `vcrt.h` and `register.h`).

```
#define DM648
```

6.5.2 Compiling and linking with the VCSBC64XX

It is advised to build your C-code as **relocatable code** (standard setting in the VC template Code Composer project files from VCRT 5.29). In this case VCRT manages the program memory allocation by itself (see Programming Tutorial for more details).

For customers who prefer absolute linking, please pay attention to the fact that the memory start address has changed in comparison to previous VC cameras. In your link file, replace the memory section with this one:

```
MEMORY
{
    PMEM:   o = 0E0100000h  l = 100000h  /* intended for initialization */
    BMEM:   o = 0E0090000h  l = 40000h   /* .bss, .system, .stack, .cinit */
}
```

6.5.3 Image capture with VCSBC64XX cameras

Picture taking with the SBC64XX camera works using the same functions as for other VC Smart Cameras (`tpict()`, `tenable()`, `capture_request()`...).

The difference is that a second image buffer is allocated at startup, for the image of the second sensor head. This second buffer is situated directly after the first image buffer in memory.

When a capture function is called, the VCSBC64XX automatically takes two images, synchronously.

This second image buffer is defined by its start address `CAPT_START2`. This system variable has been added to VCRT and can be read or modified the same way as `CAPT_START` (first image buffer).

6.5.4 IO Ports Functions

The SCB64XX camera features 8 IO ports on the Extension Connector ST7. These ports can be programmed with the following functions.

io_port_init initialize io ports to all input

synopsis `I32 io_port_init (void)`

description The function `io_port_init()` initializes all IO ports and sets them all to INPUT. This function is called automatically at camera startup.

io_port_in read inputs

synopsis `I32 io_port_in (void)`

description The function `io_port_in()` returns the input values. Only the 8 last bits of the integer value are relevant. IO_0 corresponds to the least significant bit. Input is high when bit set to 1, low when bit set to 0.

io_port_dir set port direction (input or output)

synopsis `I32 io_port_dir (int direction)`

description The function `io_port_dir()` sets the direction of the IOs. Only the 8 last bits of the integer value are relevant. IO_0 corresponds to the least significant bit. The IO is an input when bit set to 0, and an output when bit set to 1.

io_port_out set outputs

synopsis `I32 io_port_out (int out)`

description The function `io_port_out()` sets or resets the outputs. Only the 8 last bits of the integer value are relevant. IO_0 corresponds to the least significant bit. The output is low when bit set to 0, and high when bit set to 1.

io_port_int_enable enable IOPORT interrupt

synopsis `I32 io_port_int_enable (void)`

description The function `io_port_int_enable()` enables the IOPORT interrupt.

io_port_int_disable disable IOPORT interrupt

synopsis `I32 io_port_int_disable (void)`

description The function `io_port_int_disable()` disables the IOPORT interrupt. This is the default state, due to floating IOs which would constantly trigger interrupts.

Appendix A: New VCRT Functions VCSBC64XX

New VCRT functions (see section 6 and vcrt.h):

<code>int io_port_init(void);</code>	<code>/* initialize io ports to all input */</code>
<code>int io_port_in(void);</code>	<code>/* returns result - lowest 8 bits - 0=LOW 1=HIGH */</code>
<code>int io_port_dir(int direction);</code>	<code>/* returns result - lowest 8 bits - 0=INP 1=OUT */</code>
<code>int io_port_out(int out);</code>	<code>/* set output - lowest 8 bits - 0=LOW 1=HIGH */</code>
<code>int io_port_int_enable();</code>	<code>/* IOPORT interrupt enable */</code>
<code>int io_port_int_disable();</code>	<code>/* IOPORT interrupt disable */</code>

Appendix B: Spectral Transmission of IR Filter

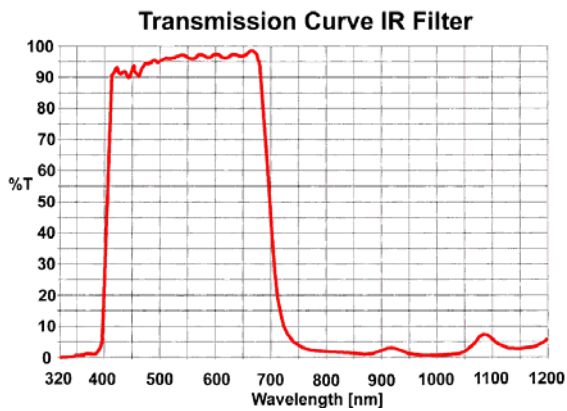

This IR cut filter is incorporated in every VCSBC64XX camera with C-mount lens holder. The IR filter can be removed if required. In this case, special care must be taken not to damage the CCD sensor.

If the camera is used without IR filter it is important to replace it by a clear glass filter of the same size. The C-mount flange distance from the CCD is accurately adjusted for the use of the IR filter – removing the filter decreases the length of the optical path and it may become impossible to focus some lenses to a larger working distance.



If the IR filter is not to be used, please order your camera with a clear glass filter or contact Vision Components for obtaining a glass filter.

The order numbers for the clear glass window is:

EK000624

The order number for the IR cut filter (standard) is:

EK000625

Appendix C: Overall Dimensions VCSBC64XX

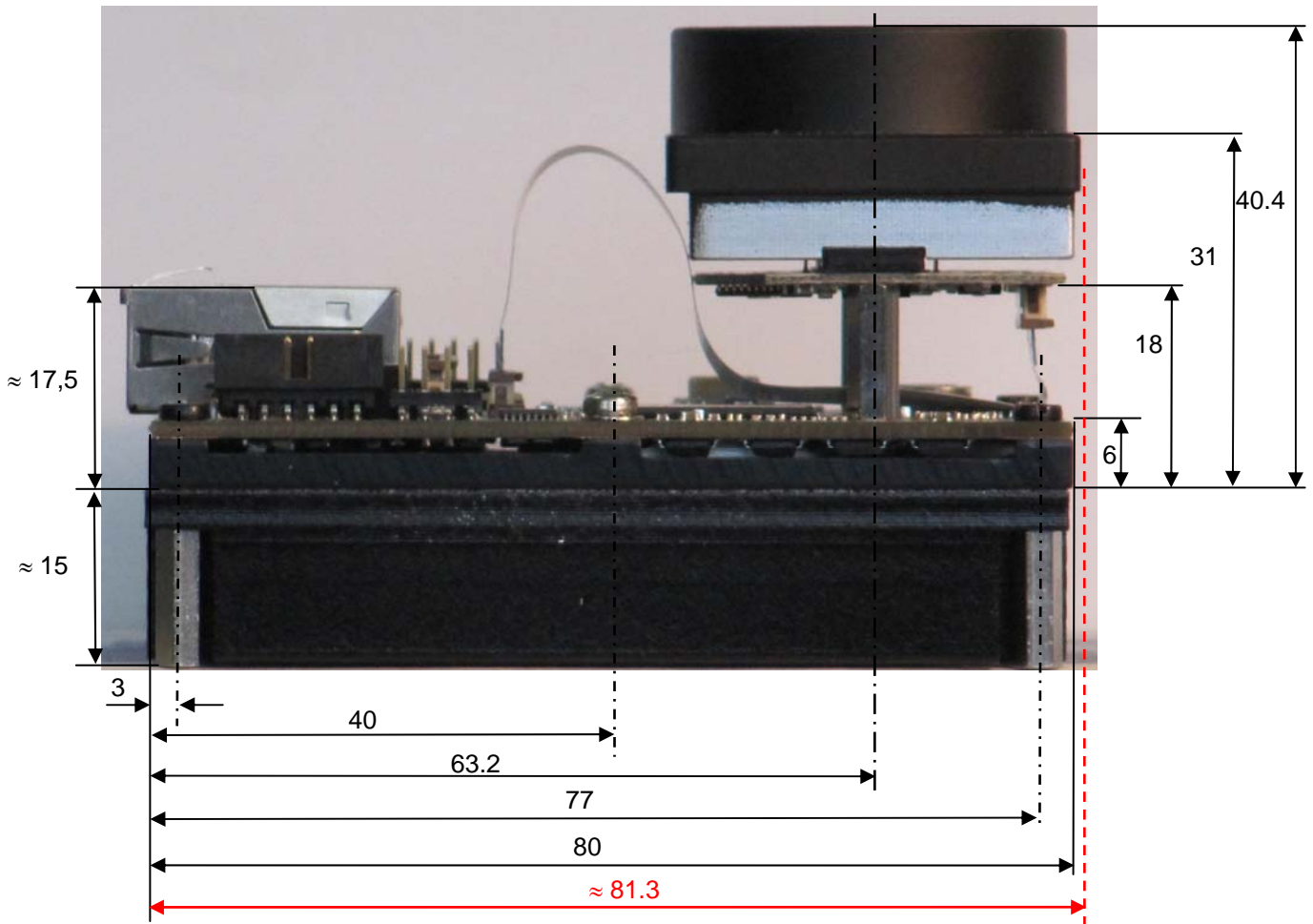

Note: the sensor head protrudes the circuit board slightly when mounted as shown!

Tolerances: All vertical dimensions: +/- 0.5mm. All horizontal dimensions: +/- 0.1mm.

Appendix D: Drawing Circuit Board VCSBC64XX

The red dot ● marks the Pin 1 position of each connector.

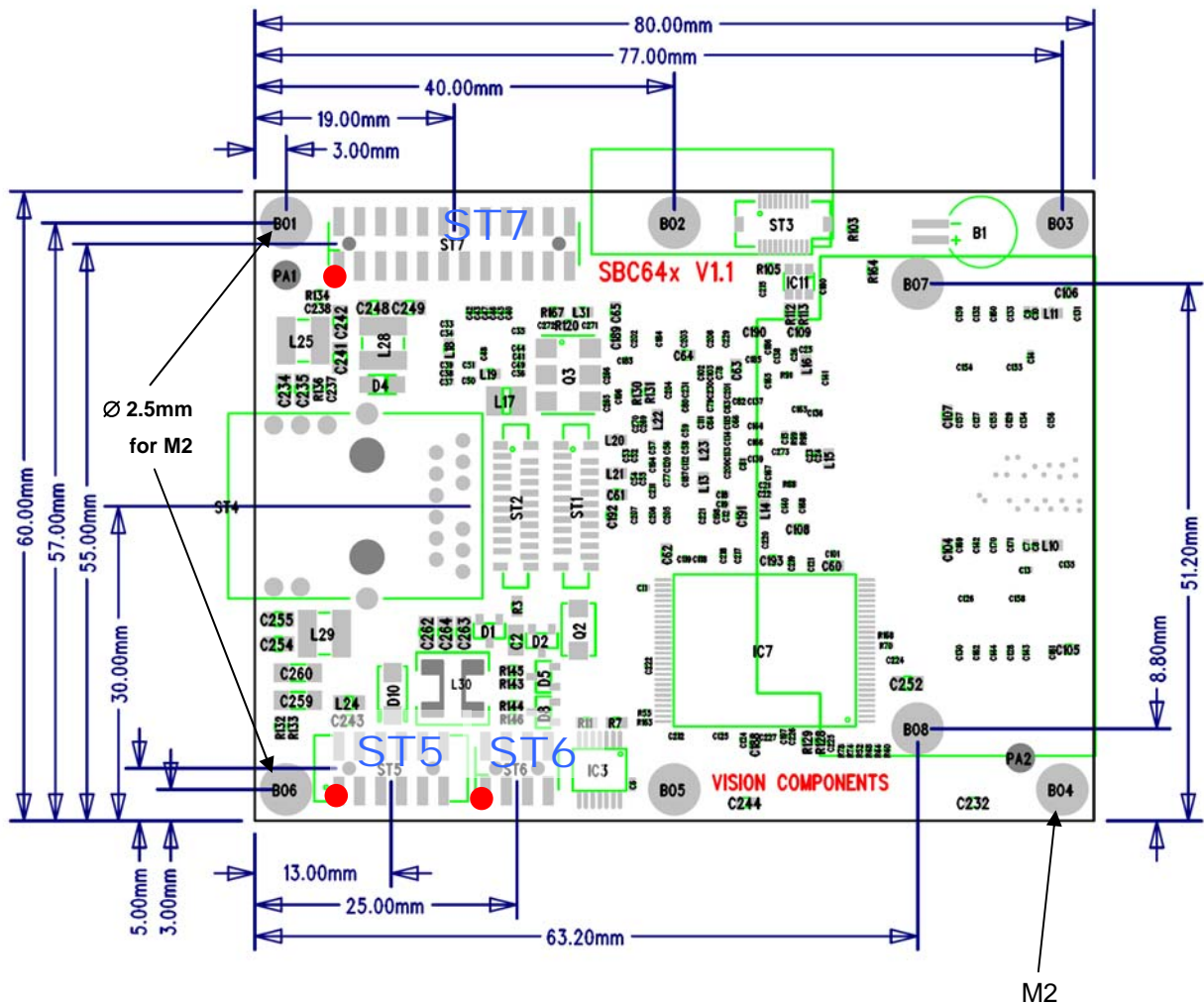

Tolerances: All circuit board dimensions: +/- 0.1mm

Appendix E: Drawing C-mount Camera Head VCSC64XX

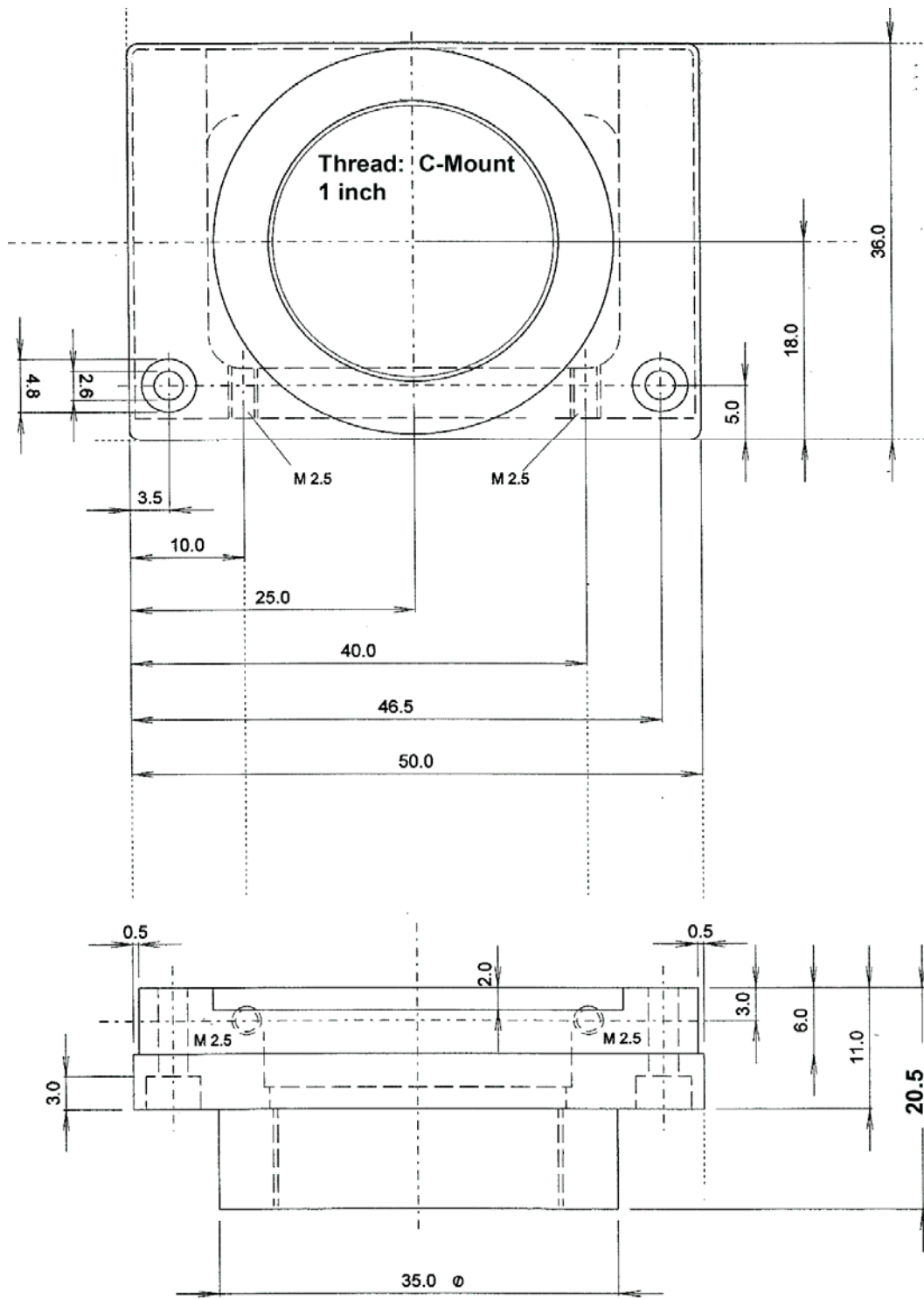

Tolerances: All dimensions: +/- 0.1mm

Appendix F: Drawing heatsink VCSBC64XX

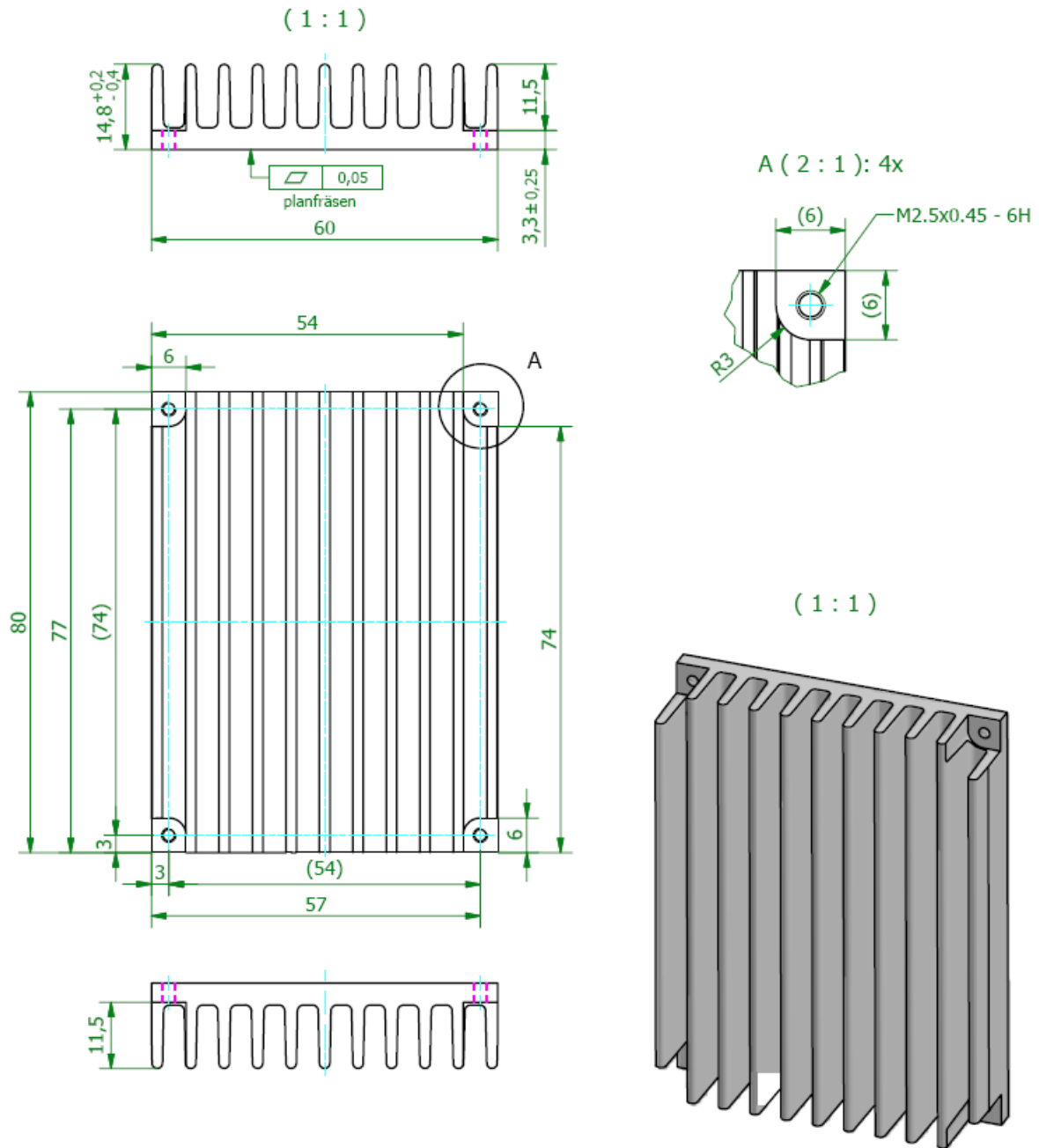

Smart Cameras made in Germany



Visit the Vision Components site www.vision-components.com for further information, documentation and software downloads:

Web Site Menu Links	Content
Home	Latest News from VC
Competences	VC Company Information VC Network
Solutions	Applications Industry
Products	Product Overview:
VC Smart Cameras	VC Base VC Professional VC Optimum VC Line Visicube VC Board Cameras VC Customized Accessories
VC Smart Camera Software	VCRT Operating System VCLIB Image Processing Library
VC Software Development Kit Ti:	
VC Special Libraries:	Color Lib Extension Lib VCOCR Text Recognition Library VC Smart Reader VC Smart Finder VC Solar Solution
News and Events	VC News Trade Show dates VC Seminars & Workshops
Service & Support:	
Contact	Contact Vision Components
Download Center	Download of:
Documentation (User Registration required)	<ul style="list-style-type: none"> - Product Brochures - Camera Manuals - Getting Started - Programming Manuals - Training Manuals and Demo Code - Software Updates (VCRT & Libs) - Demo Code - Software utilities
Software (User- and SW License Registration required)	
Tech News	Tech News – new SW and Documentation
Knowledge Base / FAQ	FAQ Database with programming Examples and Demo Code
Return / Repair Service	Form for Allocation of Repair Numbers.
Loan systems	Info about VC loan cameras